



# 2018 RV CATALOG

*Doing Our Best to Provide You the Best*

5th Wheel Hitches || Tow Dollies || Tow Bars || Braking Systems  
Tabless & Classic Baseplates || Additional Accessories

# Demco AUTOSLIDE 5<sup>TH</sup> WHEEL HITCHES

## Making Life Easy

Peace of mind. Whats that worth? With the Autoslide you will have the peace of mind that comes with towing and not having to worry about cornering in tight spaces, getting in and out of the truck to pull a pin and manually slide the hitch!

*Come rain or shine the Autoslide simply makes your life easier. Isn't that what its all about!*



Demco

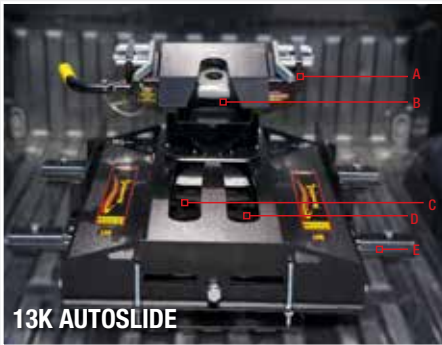

**13K AUTOSLIDE**

- A. **No locking plate required** for standard pin boxes to activate slide mechanism
- B. **Wrap around jaw** with locking bar for a smoother, safer and more secure ride
- C. **22 1/2 INCHES** of travel to help get in and out of those tight spots
- D. Up to 2 3/4" side-to-side travel to keep your pinbox from hitting bed rails or Tonneau-cover rails
- E. Industry standard bed rail mounting

PART DESCRIPTION	PART #
13K Above Mount <i>Industry Standard Bed Rails Included</i>	8550039
13K Above Bed Mount <i>Bed Rails NOT Included</i>	8550040
13K Under Bed Mount (UMS)	8550041



**18K or 21K AUTOSLIDE**

- A. **No locking plate required** for standard pin boxes to activate slide mechanism
- B. **Wrap around jaw** with locking bar for a smoother, safer and more secure ride
- C. Slides utilizing rack and pinion gear technology
- D. Up to 14" of travel to help get in and out of those tight spots
- E. **UMS (or under bed) Mounting System** leaves the bed free and clear when you remove the hitch

PART DESCRIPTION	PART #
18K Above Bed Mount <i>Industry Standard Bed Rails Included</i>	8550023
18K Above Bed Mount <i>Bed Rails NOT Included</i>	8550034
18K Under Bed Mount (UMS)	8550022
18K Under Bed Mount (UMS) <i>Ford Prep Package</i>	8550024
21K Above Bed Mount <i>Industry Standard Bed Rails Included</i>	8550036
21K Above Bed Mount <i>Bed Rails NOT Included</i>	8550035
21K Under Bed Mount (UMS)	8550037
21K Under Bed Mount (UMS) <i>Ford Prep Package</i>	8550038

**Locking Plates**

*For use with Autoslide in conjunction with a pinbox listed below*

PART DESCRIPTION	PART #
Trailair Tri Glide	6095
Trailair Flexair/Trailair Rota Flex	6171
MOR/Ryde Pinbox	6025
5 <sup>th</sup> Airborne Standard Pinbox	6026
5 <sup>th</sup> Airborne Extended Pinbox	6062
Demco Glide Ride Pinbox	6036

**Additional Autoslide Information:**

- Automatic sliding 5<sup>th</sup> wheel hitch
- Fits industry standard rails
- Low profile design
- Easy access for routine maintenance
- See page 10 for 5th wheel prep fits
- Three mounting systems to fit your needs.
- 3 vertical height adjustments to help you level truck and trailer
- 5 year warranty
- Made in the USA with American steel

*\* Frame Mounting Brackets must be ordered separately*

*\* Need locking plate with Glide Ride, Mor Ryde, Trailair Tri Glide, Trailair Flexair, Rota Flex or 5<sup>th</sup> Airborne pin boxes*

# RECON 5<sup>TH</sup> WHEEL HITCH

AVAILABLE IN GOOSENECK  
AND ISR APPLICATIONS



\* Gooseneck application shown above

**RECON** features a geometric, lightweight, two piece design. No additional adapter plates or cables needed to install on a king pin

- Fits ANY Standard 2-5/16" Gooseneck Ball Mount (Goose Neck Ball Mount must be rated at least 21K.)
- Industry standard ISR applications
- Latch handle built in – No Additional levers or rods needed to hook or unhook
- Lighter weight, two piece design for easy install and removal
- Wrap around jaw with lock bar for stronger, more secure, safer towing experience
- Dual articulation head for easy hookup and release on uneven terrain
- 3 height adjustments 15-1/2" to 18"
- 21,000 towing capacity

PART DESCRIPTION	PART #
21K Recon 5th Wheel hitch <i>Bed Rails NOT Included</i>	8550043
21K Recon 5th Wheel hitch <i>Industry Standard Bed Rails Included</i>	8550044
2 5/16 Goose Ball Mount	8550045

\* Frame mounting brackets must be ordered separately





### PREMIER SERIES HIJACKER 5<sup>TH</sup> WHEEL HITCHES

- Wrap around jaw with locking bar for a smoother, safer and more secure ride
- Long and short box applications
- 16K & 21K towing capacities
- Double pivot heads w/ polyurethane bumpers
- Powder coated finish
- Mounting kits available for most full size trucks



#### Premier Series Double Pivot

*Bed rails included. Frame mounting brackets must be ordered separately*

**16K – 8550025**  
**21K – 8550027**

- 16K & 21K towing capacities
- Long box application
- Four vertical height adjustments



#### Premier Series Double Pivot Slider

*Bed rails included. Frame mounting brackets must be ordered separately*

**16K – 8550026**  
**21K – 8550028**

- 16K & 21K towing capacities
- Short box application
- Four vertical height adjustments



#### 21K UMS Series (Under Bed Mount)

*Frame mounting brackets must be ordered separately*

**21K UMS Series – 8550032**

**21K UMS Series for Ford Prep Package– 8550033**

- 21K towing capacity
- Long box application
- Four vertical height adjustments

## SL SERIES 5<sup>TH</sup> WHEEL HITCHES



### SL SERIES HIJACKER 5<sup>TH</sup> WHEEL HITCHES

- Wrap around jaw with locking bar for a smoother, safer and more secure ride
- Long and short box applications
- 16K & 21K towing capacities
- Double pivot heads w/ polyurethane bumpers
- Powder coated finish
- Mounting kits available for most full size trucks
- Five year warranty

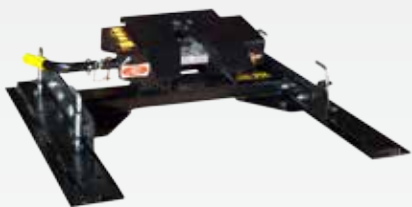

#### SL Series Flat Deck

*Bed rails included. Frame mounting brackets must be ordered separately*

**21K – 8550042**

- Double pivot head
- Wrap around jaw with locking bar for a smoother, safer and more secure ride.
  - Long/Short Box Application
  - 21,000 lb Towing Capacity
- Four vertical height adjustments



#### SL Series Double Pivot Slider

*Bed rails included. Frame mounting brackets must be ordered separately*

**16K – 8550029**

**21K – 8550030**

- Wrap around jaw with locking bar for a smoother, safer and more secure ride.
  - Long/Short Box Application
  - 16K & 21K towing capacities
  - Double pivot head with polyurethane bumpers
- Upgrade kits available to change with your towing needs





### 5th Wheel Wiring Harness

8555001 – 7'

8555002 – 10'

*Universal 5th wheel wire harness routes 7-way socket into truck bed for easy electrical hook up of a 5th wheel or gooseneck trailer. Maintains 7-way connector at rear of vehicle. Fits all current model pickups. Available in 7' or 10' lengths*



### Ultra Slide Upgrade Kits

*Upgrade to a manual slide hitch with this kit*

PART DESCRIPTION	PART #
Ultra Slide Upgrade Kit	6011
Premier Series Ultra Slide Upgrade Kit	6055



### Bed Rail Kits

PART DESCRIPTION	PART #
SL Series Bed Rail Kit	6012
Ultra Series Bed Rail Kit	6014
Premier Series Bed Rail Kit <i>Fits industry standard hitches</i>	6071



### Gooseneck Adapters

*Bed rails and frame mounting brackets must be ordered separately*

- Long Box Application
- 25,000 lb Towing Capacity
- Removes easily by pulling four pins
  - 2 5/16" ball
- Powder coated for long lasting, durable finish

PART DESCRIPTION	PART #
SL Series 25K Gooseneck	5992
Premier/Ultra Series 25K Gooseneck	5996
UMS Gooseneck	5988



### Hijacker Upgrade Kits

*Upgrade to a 21K hitch with this kit*

PART DESCRIPTION	PART #
Upgrade the 8550008, 8550009 or 8550029 to 21K towing capacity for stationary hitch	5991
Upgrade the 8550025 to 21K towing capacity for Premier Series stationary hitch	6051
Upgrade the 8550007 to 21K towing capacity for Ultra Slide	6000
Upgrade the 8550019 or 8550026 to 21K towing capacity for Premier Series Ultra Slide	6052

### Hijacker Cover- 14844

*Vinyl cover to protect the head from the elements when not using hitch*





**B&W- 6140**

*Converts the B&W ball mount to a 21K ISR rail system.  
Adjustable for bed liners*

*\*Not for use with  
automatic sliding  
hitches*



**Ford 5<sup>th</sup> Wheel Prep Bracket- 6175**

*25K rated industry standard rail system for installed  
5<sup>th</sup> wheel prep hitch package*



**Ram 5<sup>th</sup> Wheel Prep Bracket- 6099**

*25K rated industry standard rail system for installed  
5<sup>th</sup> Wheel Prep Hitch Package*



**Chevrolet/GMC 5<sup>th</sup> Wheel  
Prep Brackets**

*21K rated industry standard rail system for installed  
5<sup>th</sup> wheel prep hitch package*



6194 for 6.5' Bed

**Nissan 5<sup>th</sup> Wheel Adapter- 6200**

*21K rated industry standard rail system for installed  
5<sup>th</sup> wheel prep hitch package*



6206 for 8' Bed





# FRAME BRACKET FIT LIST

VEHICLE	YEAR	UMS-SERIES UNDER BED MOUNT	PREMIER SERIES	SL-SERIES
<b>FORD</b>				
F150 (5 1/2', 6 1/2' & 8' Boxes)	2015-2018	N/A	8552028	8553015
F150 (5 1/2', 6 1/2' & 8' Boxes)	2004-2014	8551001	8552003 or 8552004	8553002
F150 (6 1/2' & 8' Boxes)	1997-2003	N/A	8552009	8553004
F150 (6 1/2' & 8' Boxes)	1989-1996	N/A	8552005	8553005
F250/350 "Super Duty" (6 1/2' & 8' Boxes)	2017	8551009	8552031	8553017
F250/350 "Super Duty" (6 1/2' & 8' Boxes)	2011-2016	8551000	8552000	8553000
F250/350 "Super Duty"	2005-2010	8551000	8552001 or 8552002	8553001
F250/350 "Super Duty" (6 1/2' & 8' Boxes)	1999-2004	8551000	8552006	8553003
F250 "Heavy Duty" (6 1/2' & 8' Boxes)	1997-1998	N/A	8552005	8553003
F250 "Light Duty" (6 1/2' & 8' Boxes)	1997-2003	N/A	8552009	8553004
F250 (6 1/2' & 8' Boxes)	1989-1996	N/A	8552005	8553005
F350 (6 1/2' & 8' Boxes)	1992-1998	N/A	8552005	8553003
F450 "Super Duty"	2011-2016	8551000	8552000	8553000
F450 "Super Duty"	2008-2010	8551000	8552001 or 8552002	8553001
F450/550 "Chassis Cab"	2000-2007	N/A	8552005	Not recommended
F Series (6 1/2' & 8' Boxes)	1973-1988	N/A	8552005	8553003
Ranger (6 1/2' Boxes)	2000 & earlier	N/A	N/A	8553006
<b>CHEVROLET/GMC</b>				
Silverado & Sierra 1500 (5 1/2', 6 1/2' & 8' Bed) Regular, Double, and Crew Cab	2014-2018	8551008	8552027	8553014
Silverado & Sierra 1500 (6 1/2' and 8' Box) (tube frame)	2007-2013	8551005	8552009 or 8552013	8553004
Silverado & Sierra 1500 (5 1/2' Box)	2007-2013	8551008	8552009 or 8552013	8553004
Silverado & Sierra 1500 (6 1/2' & 8' Boxes)	1999-2007	8551004	8552009	8553004
Silverado/Sierra 1500 HD (6 1/2' & 8' Boxes)	2001-2007	8551004	8552009	8553004
Silverado/Sierra 1500 (5 1/2' Box)	2004-2006	8551008	8552009	8553004
Silverado/Sierra 1500 (8' Box)	1988-1998	N/A	8552009	8553009
Silverado/Sierra 1500 (6 1/2' Box)	1988-1998	N/A	8552009	8553009
Silverado/Sierra 2500 & 3500 HD (6 1/2' box only)	2011-2018	8551002	8552011	8553007
Silverado/Sierra 2500 & 3500 HD (8' box only)	2011-2018	8551003	8552011	8553007
Silverado/Sierra 2500 & 3500 HD (6 1/2' & 8' Boxes) (Includes New Body Style)	2001-2010	8551004	8552009 or 8552012	8553004
Silverado & Sierra 2500 (6 1/2' & 8' Boxes)	1999-2007	8551004	8552009	8553004
Silverado/Sierra 2500 (8' Box)	1988-1998	N/A	8552009	8553009
Silverado/Sierra 2500 (6 1/2' Box)	1988-1998	N/A	8552009	8553009
Silverado/Sierra 3500 (6 1/2' and 8' Box)	1988-2001	N/A	8552009	8553009
Chevrolet/GMC Pickups (6 1/2' & 8' Boxes)	1987 & earlier	N/A	8552014	Not recommended
Chevrolet/GMC S-10 (6 1/2' Box)	1987 & earlier	N/A	N/A	8553003
<b>DODGE</b>				
Ram 1500 (5 1/2', 6 1/2' & 8' Boxes) No Air Suspension Includes Diesel	2009-2018	N/A	8552030	8553010
Ram 1500 (4x2 & 4x4)(6 1/2' & 8' Boxes)(Includes Mega Cab)	2002-2008	8551005	8552015 or 8552016	8553004
Ram 1500	1994-2001	N/A	8552009	8553003
Ram 2500 (4x2 & 4x4)(6 1/2' & 8' Boxes) (Includes Mega Cab) (Includes Auto Level Rear Air Suspension)	2014-2018	N/A	8552025	8553016
Ram 2500 (4x2 & 4x4)(6 1/2' & 8' Boxes) (Includes Mega Cab)	2013	8551005	8552015 or 8552023	8553004
Ram 2500 (4x2 & 4x4)(6 1/2' & 8' Boxes) (Includes Mega Cab)	2003-2012	8551005	8552015 or 8552016	8553004
Ram 2500 (6 1/2' & 8' Boxes)	1994-2002	N/A	8552009	8553003
Ram 3500 (4x2 & 4x4)(6 1/2' & 8' Boxes) (Includes Mega Cab)	2013-2018	8551006*	8552026	8553013*
Ram 3500 (4x4 only)(6 1/2' & 8' Boxes) (Includes Mega Cab)	2003-2012	8551005	8552015 or 8552016	8553004
Ram 3500 (4x2 only)(6 1/2' & 8' Boxes) (Includes Mega Cab)	2003-2012	8551005	8552017	8553004
Ram 3500 (6 1/2' & 8' Boxes)	1994-2002	N/A	8552009	8553003
Ram (6 1/2' & 8' Boxes)	1993 & earlier	N/A	8552009	8553003
Dakota (6 1/2' Box)	2005	N/A	8552019	8553003
Dakota (6 1/2' Box)	2003-2004	N/A	8552005	8553003
Dakota	2002 & earlier	N/A	8552009	8553003
<b>TOYOTA</b>				
Tundra (5 1/2', 6 1/2' & 8' Boxes)	2007-2018	N/A	8552020	N/A
Tundra (6 1/2' & 8' Boxes)	2001-2006	N/A	8552009	Not recommended
Tacoma	2001 & Earlier	N/A	N/A	8553012
T100	2000 & Earlier	N/A	8552009	8553012
<b>NISSAN</b>				
Titan (5 1/2', 6 1/2', 7' & 8' Boxes)	2004-2015	N/A	8552021	N/A

**NO DRILL ATTACHMENT INDICATED IN BLUE**

*\*Not with "Auto Level Rear Air Suspension" option*

# HITCH COMPONENT FIT LIST

## HIJACKER 5TH WHEEL 13K AUTOSLIDE HITCHES

8550039	Autoslide 13K Above Bed Mnt with Industry Standard Rails Includes: 5th Wheel 13K DP Automatic Sliding 5th Wheel ultra adtr plates f/autoslide 5th Wheel set of UL bed rails no brkts	6141 6003 6071
8550040	Autoslide 13K Above Bed Mnt (Bed Rails NOT Included) Includes: 5th Wheel 13K DP Automatic Sliding 5th Wheel ultra adtr plates f/autoslide	6141 6003
8550041	Autoslide 13K Ford Prep Under Bed Mount Includes: 5th Wheel 13K DP Automatic Sliding 5th wheel UNS adapter plate 24-UAS-18	6141 6004

## HIJACKER 5TH WHEEL 18K AUTOSLIDE HITCHES

8550022	Autoslide 18K Demco 18K Under Bed Mounting System Includes: 5th Wheel 18K DP Automatic Sliding 5th Wheel UMS Adapter Plates 24-UAS-18	6077 6004
8550023	Autoslide 18K Above Bed Mnt with Industry Standard Rails Includes: 5th Wheel 18K DP Automatic Sliding 5th Wheel ultra adtr plates f/autoslide 5th Wheel set of UL bed rails no brkts	6077 6003 6071
8550024	Autoslide 18K Ford Prep Under Bed Mount Includes: 5th Wheel 18K DP Automatic Sliding 5th wheel UMS adapter plate for Reese Under Bed Mount	6077 6033
8550034	Autoslide 18K Above Bed Mnt (Bed Rails NOT Included) Includes: 5th Wheel 18K DP Automatic Sliding 5th Wheel ultra adtr plates f/autoslide	6077 6003

## HIJACKER 5TH WHEEL 21K AUTOSLIDE HITCHES

8550035	Auto Slide 21K Above Bed Mnt (Bed Rails NOT Included) Includes: 5th Wheel 21K DP Automatic Sliding 5th Wheel ultra adtr plates f/autoslide	6107 6003
8550036	Autoslide 21K Above Bed Mnt with Industry Standard Bed rails Includes: 5th Wheel 21K DP Automatic Sliding 5th Wheel ultra adtr plates f/autoslide 5th Wheel set of UL bed rails no brkts	6107 6003 6071
8550037	Autoslide 21K with Demco 18K Under Bed Mounting System Includes: 5th Wheel 21K DP Automatic Sliding 5th Wheel UMS adapter plates 21-UAS-18	6107 6004
8550038	Autoslide 21K Ford Prep Under Bed Mount Includes: 5th Wheel 21K DP Automatic Sliding 5th Wheel UMS adapter plate for Reese Under Bed Mount	6107 6033

## HIJACKER 5TH WHEEL PREMIER SERIES ABOVE BEDMOUNTING

8550025	Premier 16K DBL Pivot Stationary 5th Wheel Includes: 5th Wheel DBL Pivot Head 5th Wheel DBL Pivot Saddle 5th Wheel Set of UL Siderails 5th Wheel Set of UL Bed rails no brkts	6076 6023 6060 6071
---------	--	------------------------------

## HIJACKER 5TH WHEEL PREMIER SERIES ABOVE BED MOUNTING (CONT)

8550026	Premier 16K DBL Pivot Ultra Slide 5th Wheel Includes: 5th Wheel DBL Pivot Head 5th Wheel DBL Pivot Saddle 5th Wheel Set of Ultra Slide Side Rails 5th Wheel Set of Ultra Slide Base Rails 5th Wheel Set of UL Bed rails no brkts	6076 6023 6059 5999 6071
8550027	Premier 21K DBL Pivot Stationary 5th Wheel Includes: 5th Wheel DBL Pivot Head 5th Wheel DBL Pivot Saddle 5th Wheel 21K Upgrade Kit 5th Wheel Set of UL Siderails 5th Wheel Set of UL Bed rails no brkts	6076 6023 6051 6060 6071
8550028	Premier 21K DBL Pivot Ultra Slide 5th Wheel Includes: 5th Wheel DBL Pivot Head 5th Wheel DBL Pivot Saddle 5th Wheel Set of Ultra Slide Side Rails 5th Wheel Set of Ultra Slide Base Rails 5th Wheel 21K Upgrade Kit 5th Wheel Set of UL Bed rails no brkts	6076 6023 6059 5999 6052 6071

## HIJACKER 5TH WHEEL SL SERIES

8550029	SL Series 16K DBL Pivot Slider 5th Wheel Includes: 5th Wheel DBL Pivot Head 5th Wheel DBL Pivot Saddle 5th Wheel Set of SL Side Rails 5th Wheel Set of SL Bed rails no brkts	6076 5990 5987 6012
8550030	SL Series 21K DBL Pivot Slider 5th Wheel Includes: 5th Wheel DBL Pivot Head 5th Wheel DBL Pivot Saddle 5th Wheel Set of SL Side Rails 5th Wheel 21K Upgrade Kit 5th Wheel Set of SL Bed rails no brkts	6076 5990 5987 5991 6012
8550042	SL Series 21K DBL Pivot Flat Deck Slider Includes: 5th Wheel DBL Pivot Head 5th Wheel Flat Deck Rail Assy 5th Wheel Set of SL Bed rails no brkts	6076 6148 6012

## HIJACKER 5TH WHEEL UMS UNDER BED MOUNTING SYSTEM

8550032	UMS 21K DBL Pivot Demco Under Bed Mount 5th Wheel Includes: 5th Wheel DBL Pivot Head 5th Wheel DBL Pivot Saddle 5th Wheel Set of UM Siderails	6076 5990 6005
8550033	UMS 21K DBL Pivot Ford Prep Under Bed Mount 5th Wheel Includes: 5th Wheel DBL Pivot Head 5th Wheel DBL Pivot Saddle 5th Wheel UMS Siderail Kit for Reese Under Bed Mount	6076 5990 6040

## RECON LIGHT WEIGHT 5TH WHEEL HITCH

8550043	RECON 21K 5th Wheel Hitch (No Rails included) Includes: 5th Wheel DBL Pivot Head 5th Wheel RECON Base for ISR Rails	6169 6180
8550044	RECON 21K 5th Wheel Hitch W/ISR Bed Rails Includes: 5th Wheel DBL Pivot Head 5th Wheel RECON Base for ISR Rails 5th Wheel Set of UL Bed Rails no Brackets	6169 6180 6171
8550045	RECON 21K 5th Wheel Hitch Fits 2 <sup>5</sup> / <sub>16</sub> " Gooseneck Ball Mount Includes: 5th Wheel DBL Pivot Head 5th Wheel Recon Baseplate for gooseneck ball mount	6169 6201





**DEMCO GLIDE RIDE**

Absorbs bumps and jolts through a gravity, self-centering, parallel linkage system



- Greatly reduces stress and fatigue at the hitch point
- Maintenance Free
- Doesn't affect braking or steering
- Helps prolong the life of your truck and RV
- Makes a smoother, more pleasant ride
- Available in several different pin box widths
- Rated up to 21,000 lbs G.V.W.R.

PART DESCRIPTION	PART #
Fabex 500, 503, 765	8250001
Fabex 530,730	8250002
Lippert 1621	8250008
Leland 7910	8250010
Leland 7920	8250011
Venture (short) 13515, 13517	8250012
Venture (long) 13515, 13517	8250013
Fabex 520	8250014
12" no mounting holes	8250017
Lippert 1716	8250018
Fabex 665	8250019
Youngs Welding (medium)	8250020
Lippert 1116	8250021
Youngs Welding (long)	8250022
Youngs Welding (8.5" - 9"wide)	8250023

## VICTORY SERIES TOW BARS



### VICTORY SERIES TOW BARS (Dominator, Excali-Bar II & Commander)

- Independent self-supporting arms
- Easy trigger release
- Adjustable towing angle
- Rise or Drop male receiver
- Safety cables are included with all Demco tow bars



### **Dominator™**

#### 9511008 – Dominator™

- Weighs only 30 lbs.
- Tows up to 7,500 lbs.



### **Excali-Bar II™**

#### 9511009 – Excali-Bar II™

- Weighs only 46 lbs.
- Tows up to 10,500 lbs.



### **Commander™**

#### 9511010 – Commander™

- Weighs only 41 lbs.
- Tows up to 6,000 lbs.



**Kwik-Tow**

#### 9511011 – Kwik-Tow™

Another tow bar available to you from Demco is the **Kwik-Tow**. The Kwik-Tow is an alternative for those looking for the most basic, inexpensive option Demco has to offer.

*Features include: 2" Ball coupler type, Class III, Up to 5000 lbs. towing capacity, Arms adjust from 20" to 36.5", Safety cables are included with all Demco tow bars and a Limited Lifetime Warranty.*



**Safety Cable Mounting Clips**

- Ensures tow bar's vinyl covered safety cables are attached securely out of the way

**Independent Arms for Easy Hook-Up**

- True independent arm movement

**Self-Supporting Arms**

- When unfolded, they will not fall to the ground. Makes hooking up faster and easier

**Rise or Drop Male Receiver**

- 1 1/2" rise/drop receiver tube

**Easy Trigger Release**

- No extra tools required for hook-up or release - truly non-binding



- Versatile design permits multiple storage positions
- Independent arm movement enables user to store it to the right, left, or one leg each way
- Able to be stored on the motorhome

**DEMCO IS THE ONLY MANUFACTURER TO OFFER A LIMITED LIFETIME WARRANTY**

- Demco Tow Bars have a Limited Lifetime Warranty to be free from defects in materials and workmanship under normal use and service from date of purchase by the original (first) retail owner, or until it is resold or transferred by the original owner.
- Any part of the Demco Tow Bar found in the judgment of the manufacturer to be defective in materials or workmanship will be repaired or replaced at the manufacturer's discretion without charge for parts or labor to the original owner.



# TOW BAR ACCESSORIES



9523057



9523051



9523003



9523064

PART DESCRIPTION	PART #
<b>TOWING COMBO KITS:</b>	
Diode System Combo Kit <i>*Kit includes</i>	9523057
* 6 Way Coiled Lighting Cable	
* Diode Wiring Kit	
* Marine Grade, Vinyl Demco Storage Cover	
* Three Pin Locking Kit	
* 7 to 6 Way Adapter	
Bulb/Socket Combo Kit <i>*Kit includes</i>	9523058
* 6 Way Coiled Lighting Cable	
* Bulb & Socket Wiring Kit	
* Marine Grade, Vinyl Demco Storage Cover	
* Three Pin Locking Kit	
* 7 to 6 Way Adapter	

PART DESCRIPTION		PART #
<b>SAFETY CABLES:</b>		
54" Straight Safety Cables	<i>* Sold Per Pair</i>	9523051
64" Straight Safety Cables	<i>* Sold Per Pair</i>	9523055
86" Coiled Safety Cables	<i>* Sold Per Pair</i>	9523003
12" Safety Cable Extensions	<i>* Sold Per Pair</i>	9523064
18" Safety Cable Extensions	<i>* Sold Per Pair</i>	9523065



9523067



9523068



9523066

PART DESCRIPTION		PART #
<b>LOCKING PINS:</b>		
5/8" Locking Hitch Pin	<i>* Sold Per Pair</i>	9523066
Two Locking Baseplate Pins	<i>* All keyed alike</i>	9523067
Three Pin Locking Kit	<i>* All keyed alike</i>	9523068
Two Quick Pins	<i>* Sold Per Pair</i>	9523045
Two Standard Pins w/ Quick Pins	<i>* Sold Per Pair</i>	9523046

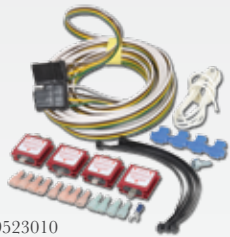

9523010



9523047

PART DESCRIPTION	PART #
<b>WIRING KITS:</b>	
Towed Vehicle Taillight Wiring/Diode Kit	9523010
Bulb Taillight Wiring Kit	9523047
7 to 6 RV Adapter	9523053
Light Bar	KKLB
Diode Kit	9523063



9523052

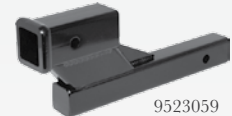

9523059

PART DESCRIPTION		PART #
<b>ACCESSORIES:</b>		
3 1/2" Receiver Extension		9523052
4" Drop/Raise Receiver for Victory Series Tow Bars		9523059
6" Drop/Raise Receiver for Victory Series Tow Bars		9523060
Tow Bar Storage Cover		9523042
Pull Ear Covers	<i>* Sold Per Pair</i>	5899



PART DESCRIPTION	PART #
<b>FLEX-COILED WIRING CABLES:</b>	
4 Way Coiled Lighting Cable	9523004
6 Way Coiled Lighting Cable	9523006
7 to 6 Way Coiled Lighting Cable	9523054
7 to 4 Way Coiled Lighting Cable	9523069



9523027



9523061

PART DESCRIPTION	PART #
<b>SENTRY DEFLECTOR ADAPTERS:</b>	
For Stowmaster™, Blue Ox™ RV mounted tow bars to Roadmaster™ baseplate	9523027
For Blue Ox baseplate	9523061





### Towed Vehicle Protection

There's a world of difference between the comfort behind the steering wheel of your motorhome and the raw elements behind your rear bumper. Elements like loose gravel, road tar and other road debris get hurled at high velocity toward your towed vehicle. The Sentry® Tow Bar Deflector is constructed of resilient, high density polyethylene and is attached to the connecting ears of the Demco Tow Bar.

### Sentry Deflector™ for Tow Bars – 9523135

- Unique position and 30° angle deflect debris down and away from your vehicle. Messy cleanup and costly paint chip repair are minimized
- High density polyethylene retains its shape and takes destructive abuse
- Lightweight, but strong, the Sentry® Deflector is durable, yet pliable and flexible
- Easy to install or remove, it assembles from three parts that lock together (no tools required)
- Fringed bottom edge allows more flexibility. Minimizes damage to deflector caused by curbs and extreme dips and bumps

## TABLESS BASEPLATES



UNHOOKED



INSERT TAB



TURN 1/4 TURN



PIN INSERTED

Displayed on a Chevy Malibu



Displayed on a GMC Sierra

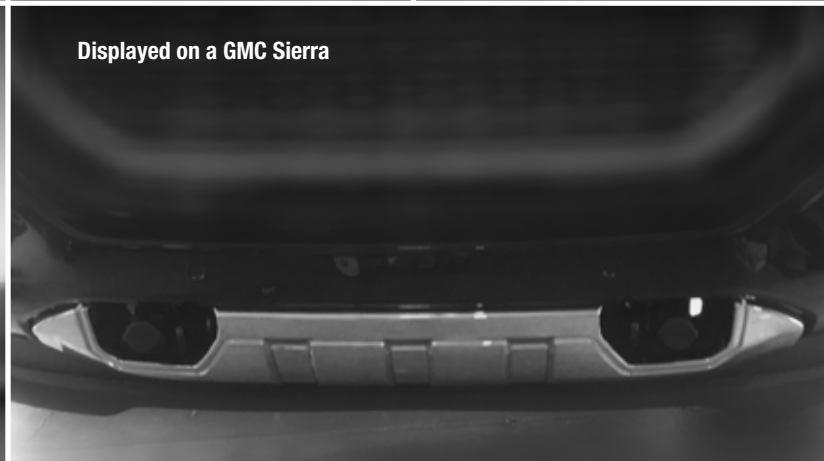

At Demco we strive to develop and bring to market, not just new, but innovative products. We believe the Tabless baseplate is that type of innovative product! Never again will you have to look at a baseplate sticking out of the front of your tow car or have to look for the lost tabs that aren't attached to anything when you remove them. Demco has introduced the towing innovation of Tabless baseplates. Your towed car will have that clean front just like the day you purchased it and the tabs will forever remain attached to your tow bar and right where you need them when it's time to hit the road for that next adventure!

## TABLESS BASEPLATE ADAPTERS

\* Adapts Demco tabless baseplates to other manufacturers' tow bars

PART DESCRIPTION	PART #
Roadmaster tow bar (fits Tracker, Sterling All-Terrain, Black Hawk 2 All-Terrain Falcon All-Terrain)	<i>No adapter needed</i>
Blue Ox towbar (excludes Ambassador)	9523127
Demco Kwik-Tow	9523128



- Revolutionary new tabless design from Demco
- Practically invisible
- Tabs stay on the tow bar
- Never lose a tab again!
- Easy hook-up and disconnect
- Demco tabless baseplates will work with other manufacturer's tow bars, with and without adapters.
- Bolts permanently to the chassis of the towed vehicle and provides secure, reliable attachment point for all Demco tow bars
- Tabless baseplates available for many models.  
*Check with your dealer or Demco website for availability*







**Tabless baseplates may not fit every vehicle design. Demco continues to offer our Classic Style Baseplates**

- Bolts permanently to the chassis of the towed vehicle and provides a secure, reliable attachment point for all Demco tow bars.
- Hook to a Demco baseplate is easy - two attaching pins with quick pins and two safety cables with safety hook retainers
- Check with your dealer or Demco website for the fit for your vehicle.



Plastic Baseplate Pull Ear Covers  
5899



**CLASSIC STYLE BASEPLATE ADAPTERS**

*\* Adapts Demco tow bars to other manufacturers' baseplates*

PART DESCRIPTION	PART #
Roadmaster Baseplates including XL or EZ Series	9523001
Duncan Baseplate	9523017
Reese® Tow Champ & Valley Ind. Utility Tow Bar, Bumper Brackets	9523019
Roadmaster MS or MX Series Baseplates	9523032
Blue Ox Baseplates	9523041

**CLASSIC STYLE BASEPLATE ADAPTERS**

*\* Adapts Demco baseplates to other manufacturers' tow bars*

PART DESCRIPTION	PART #
Roadmaster Eagle™ & Eagle 8000™	9523014
Valley Ind. Utility Tow Bar & Reese® Tow Champ	9523015
Roadmaster Falcon 5250	9523023
Blue Ox® Aladden®, Aventa® II, Aventa® LX and Lexus	9523034
Roadmaster Tracker, Falcon 2, Falcon All Terrain, Blackhawk and Blackhawk All Terrain™ and Sterling™ tow bars with serial numbers up to 14,500	9523036
Roadmaster Sterling All Terrain™ & Sterling Tow Bars with Serial #'s above 14,501	9523062



# #1 in Towed Vehicle Braking Systems



## AIR FORCE ONE

- Proportional
- Only air brake to meet DOT and chassis regulations
- Fits every car and motorhome \*
- No pulleys, catches, or springs
- Breakaway integrated
- Industry leading 5 year warranty

*\* Requires Air Brakes on Motorhome*

100% PROPORTIONAL BRAKING, 100% HASSLE FREE

9599007 Air Force One Braking System  
6271 Air Force One, Second Car Kit\*

For Air Brake  
Motorhomes  
US Patent 7,699,406



## STAY-IN-PLAY DUO

- Dual-signal progressive activation
- Fits every car and motorhome
- No pulleys, catches, or springs
- Breakaway integrated
- Industry leading 5 year warranty

UNMATCHED RELIABILITY, UNMATCHED EASE

9599006 Stay in Play Duo Braking System

For Hydraulic Brake  
Motorhome  
US Patent 6,644,761





## DELTA FORCE

- Dual-signal proportional
- Flexball actuator mount
- Wireless coachlink
- Set-It-Once Pedal Clamp
- 75% smaller than competitor models
- Breakaway integrated
- Industry leading 5 year warranty

Universal Portable  
Solution

BIG BRAKING POWER, 1/4 THE SIZE

9599004 Delta Force Braking System  
6221 Delta Force 2nd Car Kit



## WIRELESS COACHLINK

- Plugs into coach power port
- Instant visual feedback that brakes are applied
- Transmits signal from towed-vehicle
- Positive "Brakes on" light
- Audible tone indication lets you know your SMI system is working flawlessly

Universal for all  
Braking Systems



UNIVERSAL FOR ALL BRAKING SYSTEMS

9599005 Wireless Radio Set



# TOWED CONNECTORS

**No Slicing. No Mistakes.**

*The Industry's Best Direct Plug-in Electrical Hook-Up for Your Towed Vehicle*



MAKE/MODEL	YEAR	DESCRIPTION	PART #
<b>BUICK</b>			
Enclave	13-17		9523117
Enclave	08-12		9523141
Rainier	04-07		9523071
<b>CADILLAC</b>			
Escalade	02-06		9523132
Escalade	07-12	2 Wheel Drive Only	9523098
<b>CHEVROLET</b>			
Avalanche	02-06		9523132
Avalanche	07-12	1500 Series	9523072
Cruze	11-15		9523106
Cobalt	08-10	Sport 2 Dr	9523140
Cobalt	05-10	4 Door No Turbo	9523073
Cobalt	05-10	2 Door	9523140
Colorado	04-12		9523074
Colorado	15-16		9523121
Equinox	10-17		9523142
HHR	06-11	No 'SS' or Turbo Models	9523140
Malibu	08-12	No LTZ	9523141
Malibu	13-15	No LTZ	9523108
* Pick-up	07-13	1500, 2500, 3500 Series	9523132
Sonic Sedan	12-16	Includes Hatchback	9523102
Suburban	03-06	1500 Series	9523132
Suburban	07-13	1500 Series	9523098
Tahoe	03-06	1500 Series - No Hybrid Models	9523132
Tahoe	07-12	1500 Series - No Hybrid Models	9523098
Traverse	09-12		9523141
Traverse	13-17		9523113
Trailblazer	02-08	Including 'EXT' Models	9523071
<b>DODGE</b>			
Nitro	07-11		9523144
Ram 1500	09-13	4X4 Only Non LED	9523079
Ram 1500	13-15	4X4 Only With LED	9523114
<b>FIAT</b>			
Fiat 500	13-17		9523123
<b>FORD</b>			
Edge	07-10		9523133
Edge	11-13		9523136
Escape	08-12		9523133
Escape	13-16		9523110
F-150	09-14		9523133
Fiesta	11-13	Sedan	9523116
Flex	09-18	No Eco Boost	9523081
Focus	12-17	Sedan	9523138
Focus	12-14	Hatchback	9523139
Fusion	06-12	Includes Hybrid	9523082
Fusion	13-18	Includes Hybrid	9523119
Ranger STX	05-11	Includes Hybrid	9523133

*\*Some cutting required*

MAKE/MODEL	YEAR	DESCRIPTION	PART #
<b>GMC</b>			
Acadia	07-12	Includes Acadia Denali	9523083
Acadia	13-16		9523117
Canyon	04-12		9523074
Canyon	15-16		9523121
Envoy	02-09	Including 'XLT' and 'XUV'	9523071
Terrain	10-17		9523142
Yukon	07-12	1500 Series	9523098
* Sierra	07-13	1500, 2500, 3500 Series	9523132
<b>HONDA</b>			
CRV	02-06		9523084
CRV	07-11		9523146
CRV	12-16		9523130
Element	07-11		9523086
Fit	09-13		9523147
<b>JEEP</b>			
Cherokee	14-17	Includes Trailhawk	9523134
Compass	11-16		9523107
Liberty	02-07		9523143
Liberty	08-12		9523144
Grand Cherokee	99-04		9523089
	05-06	No SRT 8	9523090
	07-11	No SRT 8	9523145
	14-18		9523115
Wrangler	98-02	Including Sport	9523092
Wrangler	98-06	Including Single & Double Tube Bumper, Rubicon, and Unlimited	9523131
Wrangler	07-17		9523129
<b>LINCOLN</b>			
MKX	07-10		9523133
MKX	11-15		9523137
<b>MAZDA</b>			
Tribute	08-11		9523133
<b>MERCURY</b>			
Mariner	08-11	Including Hybrid Models	9523080
<b>OLDSMOBILE</b>			
Bravada	02-04		9523071
<b>PONTIAC</b>			
G5	07-10		9523140
G5 Pursuit	05-06		9523140
<b>SATURN</b>			
Aura	07-09		9523094
Ion	05-07		9523095
Vue	02-07	No VTI	9523101
Vue	08-10		9523096
<b>SUZUKI</b>			
Grand Vitara	06-12		9523097
<b>TOYOTA</b>			
Rav-4	06-12		9523126
Rav-4	06-12		9523126



**Durable Galvanized Finish**

- For years of corrosion free use

**Hydraulic Surge Disc Brake System**

- Provides safe, controlled stopping

**Custom Chrome Wheels**

- Radial tires make this dolly one you'll be proud of for years to come

**Hinged Tongue**

- Hitch folds back to promote minimal storage capacity

**Tilt-bed Frame**

- Provides fast, easy loading. Positive locking mechanism on tilt-bed; does not require a separate loose pin

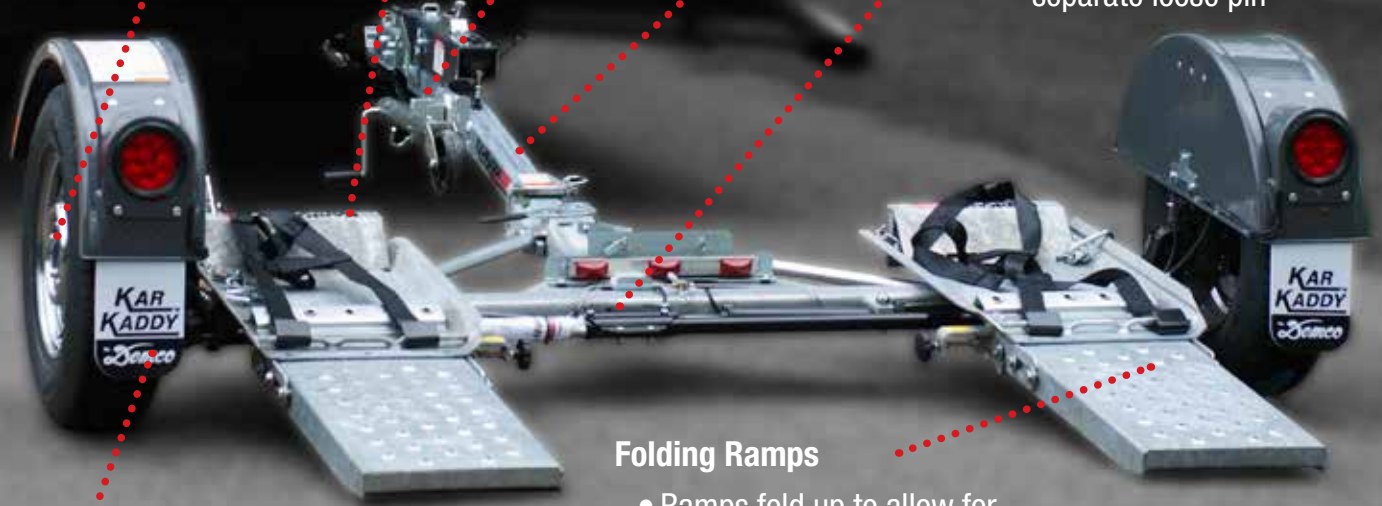

**Folding Ramps**

- Ramps fold up to allow for comfortable fit in almost any RV park or garage

**Auto Steer**

- Steerable axle allows for tighter turns



**Before**

**Unfolded Kar Kaddy™ SS length is 133"**

Many RV park lots are not deep enough to accommodate your motorhome and tow dolly.



**After**

**Folded Kar Kaddy™ SS length is 67"**

By using only half the space, you can fit both the motorhome and tow dolly comfortably in almost any RV lot. Or you can store your tow dolly in front of your car in your garage at home.

## TOW DOLLIES



- EZ-Latch coupler
- Disc brakes
- Hydraulic surge brake system
- Sealed bearing hubs with a 3-year unlimited warranty
- Radial tires and dual safety chains
- Less than 100 lbs. tongue weight when loaded, for improved ride and handling of towed vehicles
- Lowest loading clearance on the market

**KARKADDY™**

### **KARKADDY™ SS**



#### **9713045 – Kar Kaddy™ SS (w/Surge Brakes)**

- Fully extended= 133 inches long
  - Folded= 67 inches long
    - Auto Steer
  - Total towed vehicle weight: 4,800 lbs.
  - Axle capacity: 3,500 lbs.
- Towed vehicle tread width: 42" min., 76" max.
  - Galvanized finish

### **KARKADDY™ 3**



#### **9713046 – Kar Kaddy™ 3 (w/Surge Brakes)**

- Axle capacity: 3,500 lbs.
- Total towed vehicle weight: 4,800 lbs.
- Towed vehicle tread width: 42" min., 76" max.
  - Auto Steer
- Black powder coat paint finish, with hot dipped galvanized components

### **TOW-IT™ 2**



#### **9713047 – Tow-It™ 2 (w/Surge Brakes)**

- 5th Wheel design swivel platform
- Towed vehicle tread width: 42" min., 68" max.
- Black powder coat paint finish, with hot dipped galvanized components

*\* For detailed product specifications, see page 26*





**Quality Protection**

There's a world of difference between the comfort behind the steering wheel of your motorhome and the raw elements behind your rear bumper. Elements like loose gravel, road tar and other road debris get hurled at high velocity toward your towed vehicle.

**Sentry Deflector™ for Tow Dollies – 5950**

- Unique position and 30° angle deflect debris down and away from your vehicle. Messy cleanup and costly paint chip repair are minimized
- High density polyethylene retains its shape and takes destructive abuse
- Lightweight, but strong, the Sentry® deflector is durable, yet pliable and flexible
- Easy to install or remove, it assembles from three parts that lock together (no tools required)
- Fringed bottom edge allows more flexibility - minimizes damage to deflector caused by curbs and extreme dips and bumps

Additional Tow Dolly Accessories:

PART DESCRIPTION	
Wheel Jack	11683
Light Bar	KKLB
Loading Winch w/Strap Assembly	KK2W
Spare Tire Mount (black)	RKSTM
Spare Tire w/Chrome Rim	5968
Spare Tire w/White Rim	5965
Steering Wheel Strap	5975



11683



KKLB



KK2W



RKSTM



5975



## TOW DOLLY SPECIFICATIONS

### **Kar Kaddy 3** Standard Equipment Includes:

Transport frame, attached loading ramps, auto-steer style tie rod system with special gas filled steering dampener, two basket style polyester tie-down straps, two tie-down winches with built in ratchet handles and safety pins, two towed vehicle safety chains, two transport vehicle safety cables, radial tires, full fenders with flaps, rally wheels, sealed combination LED stop-tail-turn lights, LED center cluster and license plate light, license plate mounting bracket, LED amber front marker lights, fender side reflectors, 2" ball coupler.

### **KK370SB - 8 1/2' WIDE AUTO TRANSPORT WITH BRAKES**

- Hydraulic surge disc brakes
- Overall width - 101"
- Overall length - 131"
- Tires - ST205/75R14 load range (C) BSW radial tire
- Wheels - 14" x 5.5"
- Weight - 520 lbs.
- Axle capacity - 3,500 lbs.
- Towed vehicle tread width - Min. - 42", Max. - 76"
- Maximum towed vehicle body width - 76"
- EZ-Latch coupler rating - 10,000 lbs.
- Total towed vehicle weight - 4,800 lbs.
- GVWR (unit weight plus max. carrying capacity) - 3,500 lbs.



CAUTION: Read your motor vehicle owner's manual to determine proper towing procedure. All vehicles must be towed with the front axle on the auto transport.

### **Kar Kaddy SS** Standard Equipment Includes:

KK460SS standard equipment is the same as the KK370 plus wheel jack, galvanized and folds for storage.

### **KK460SS - 8 1/2' WIDE AUTO TRANSPORT WITH BRAKES**

- Hydraulic surge disc brakes
- Overall width - 101"
- Overall length unfolded - 133"
- Overall length folded - 67"
- Tires - ST205/75R14 load range (C) BSW radial tire
- Wheels - 14" x 5.5-5" Nickel Chrome
- Weight - 615 lbs.
- Axle capacity - 3,500 lbs.
- Towed vehicle tread width - Min. - 42", Max. - 76"
- Maximum towed vehicle body width - 76"
- EZ-Latch coupler rating - 10,000 lbs.
- Total towed vehicle weight - 4,800 lbs.
- GVWR (unit weight plus max. carrying capacity) - 3,500 lbs.



CAUTION: Read your motor vehicle owner's manual to determine proper towing procedure. All vehicles must be towed with the front axle on the auto transport.

### **Tow-It 2** Standard Equipment Includes:

Heavy-duty frame, attached loading ramps, two basket style polyester tie-downs, two tie-down winches with built in ratchet handles and safety pins, two towed vehicle safety chains, two transport vehicle safety cables, radial tires, full fenders, rally wheels, sealed combination stop-tail-turn lights, fender side reflectors, 2" ball coupler.

### **TI210SB - 8" WIDE AUTO TRANSPORT WITH BRAKES**

- With Hydraulic Surge Brakes
- EZ-Latch coupler rating - 10,000 lbs.
- Overall width - 95"
- Overall length - 131"
- Tires - ST205/75R14 load range (C) BSW radial tire
- Wheels - 14" x 5.5"
- Weight - 510 lbs. (TI210 assembled)
- Axle capacity - 3,500 lbs.
- GVWR (unit weight plus max. carrying capacity) - 3,500 lbs.
- Towed vehicle tread width - Min. - 42" (inside to inside of tire), Max. - 68" (outside to outside of tire)
- Total towed vehicle weight - 4,800 lbs.
- Maximum towed vehicle body width - 68"



CAUTION: Read your motor vehicle owner's manual to determine proper towing procedure. All vehicles must be towed with the front axle on the auto transport.

All vehicles to be towed on Demco Auto Transports must be towed with the front axle on the dolly. Some cars may be too wide in the body area to properly fit on an 8' wide auto transport even though the front tire measurement is 68" or less (the 1992 Oldsmobile 88 and 98 are examples).

If you are planning to tow a new or late model full size car, we would recommend the 8 1/2' wide KK370SB or KK460SS.

Always follow weight limitations when choosing a Demco Auto Transport.

8 1/2' wide auto transports may be subject to width restrictions on roads in some states.

